

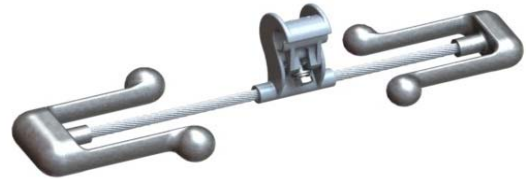

Industrias Arruti

STOCKBRIDGE DAMPERS

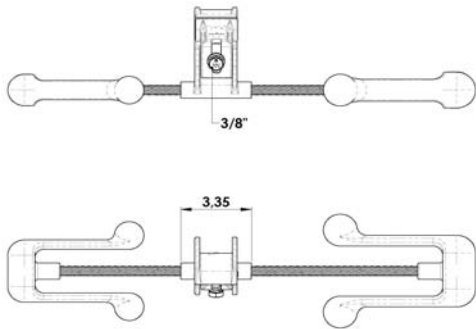

Material: Clamp: Alloy A1. EN-1706 (similar to ANSI A413.0).
 Keeper: Alloy A1. EN-1706 (similar to ANSI A413.0).
 Masses: Forged steel EN-10083 (similar to ASTM A576).
 Steel Parts finish: Hot dip galvanising ASTM A153.

Bolt: ASTM A325.
Nut: ASTM A563.

Reference	Clamp	Big	Small	Ø Conductor (inch)		Weight (lb)
		Mass	Mass	Min.	Max.	
SD-0302-Ø13/AM	SD-Ø13	DMP-3	DMP-2	0,28	0,51	4,03
SD-0302-Ø20/AM	SD-Ø20	DMP-3	DMP-2	0,51	0,79	4,17
SD-0302-Ø27/AM	SD-Ø27	DMP-3	DMP-2	0,79	1,46	4,25
SD-0403-Ø20/AM	SD-Ø20	DMP-4	DMP-3	0,51	0,79	6,68
SD-0403-Ø27/AM	SD-Ø27	DMP-4	DMP-3	0,79	1,46	6,77
SD-0403-Ø34/AM	SD-Ø34	DMP-4	DMP-3	1,06	1,34	6,9
SD-0403-Ø44/AM	SD-Ø44	DMP-4	DMP-3	1,34	1,73	7,08
SD-0504-Ø20/AM	SD-Ø20	DMP-5	DMP-4	0,51	0,79	9,33
SD-0504-Ø27/AM	SD-Ø27	DMP-5	DMP-4	0,79	1,06	9,41
SD-0504-Ø34/AM	SD-Ø34	DMP-5	DMP-4	1,06	1,34	9,55
SD-0504-Ø44/AM	SD-Ø44	DMP-5	DMP-4	1,34	1,73	9,72
SD-0605-Ø34/AM	SD-Ø34	DMP-6	DMP-5	1,06	1,34	14,09
SD-0605-Ø44/AM	SD-Ø44	DMP-6	DMP-5	1,34	1,73	14,15