

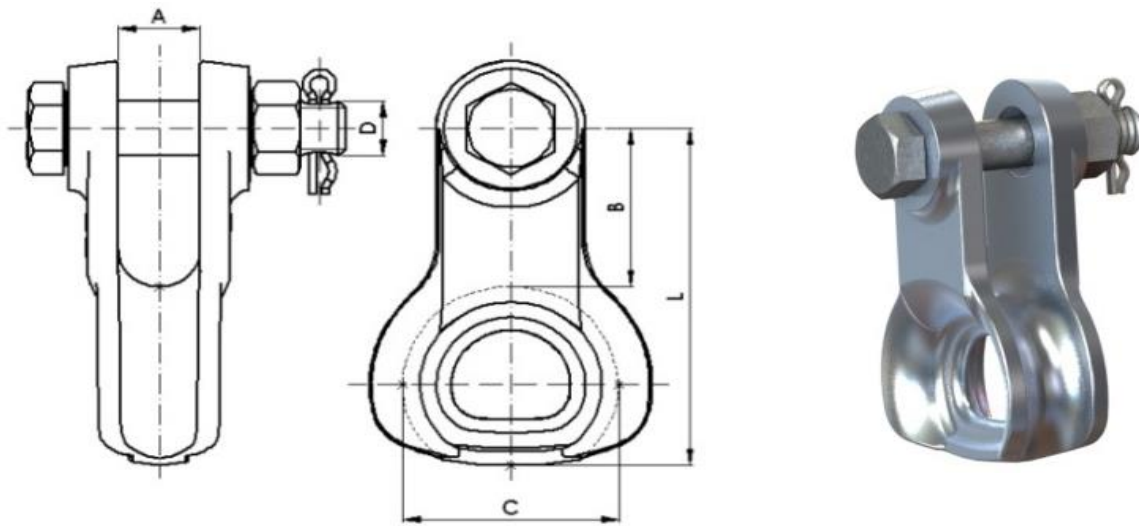

Industrias Arruti

**07. PREFORMED CLAMPS FOR ALUMOWELD CABLES**

**THIMBLE**



Material: Nodular cast EN-1563 (similar to ASTM A536).					Locking Pin: Stainless Steel (AISI 304)		
Steel parts finish: Hot dip galvanising ASTM A153.					Bolt: ASTM A325		Nut: ASTM A563.
Reference	Dimensions (inch)					Ultimate strength	Weight
	A	B	C	D	L	(lb)	(lb)
<b>G-16/AM</b>	0,87	1,85	2,28	5/8	3,94	28.000	1,7