

This drawing is property of I. Arruti and must not be copied, exhibited or furnished without the written consent of I. Arruti

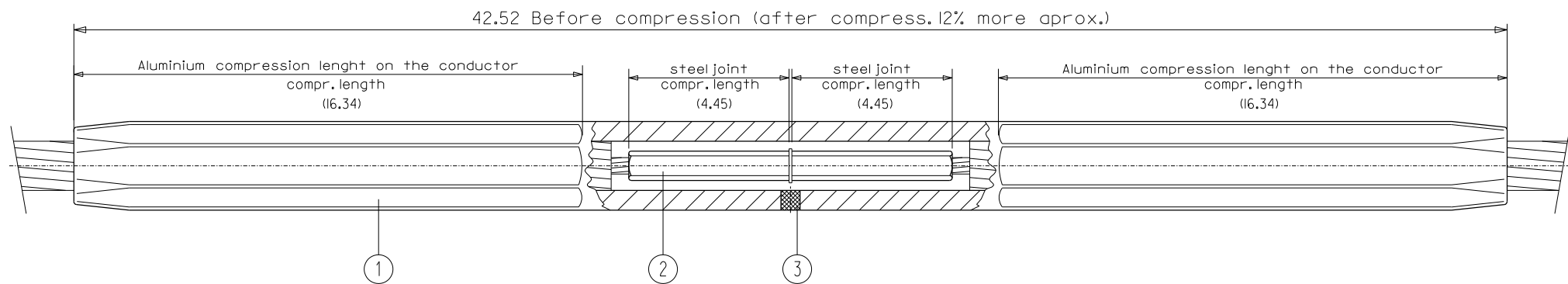

MARKS	
-	& LOT
-	REFERENCE OF THE CLAMP
-	CONDUCTOR NAME
-	MIN. RECOMMENDED PRESS
-	DIE SIZE
-	COMPRESSION AREA

DIMENSIONS BEFORE COMPR.

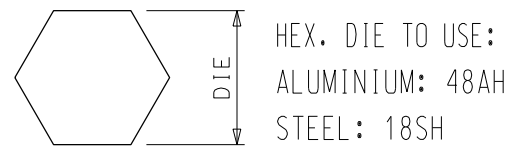
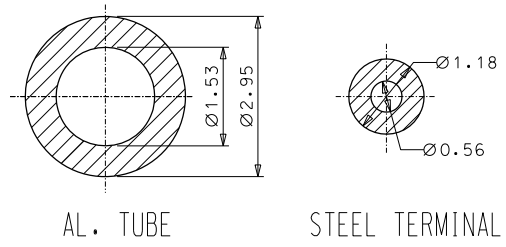

ARCHIVO:usacompression

- Notes:**
- Hot dip galvanized according to ASTM A153
  - Tolerances unless otherwise stated to be up to and including 1.4" ±0.027 Over 1.4" ±2%
  - All dimensions in inches

MOD.		DATE		MODIFICATION				DRAWN BY	
		F 40513		NAME		CODE			
						FULL TENSION COMPRESSION JOINT EC-931-SS/TW/AM FOR ACSS/TW PECOS CONDUCTOR			
N QTY		DENOMINATION		MATERIAL		UNIT (inch)		Aprox. Weight: 14.75 lb U.S.: 95% of conductor R.B.S.	
								SCALE	
				CHECKED		I.L.		I-09-20	
						D/S		EC931SSTWAM	
								ISSUE	
								0	