

This drawing is property of I. Arruti and must not be copied, exhibited or furnished without the written consent of I. Arruti

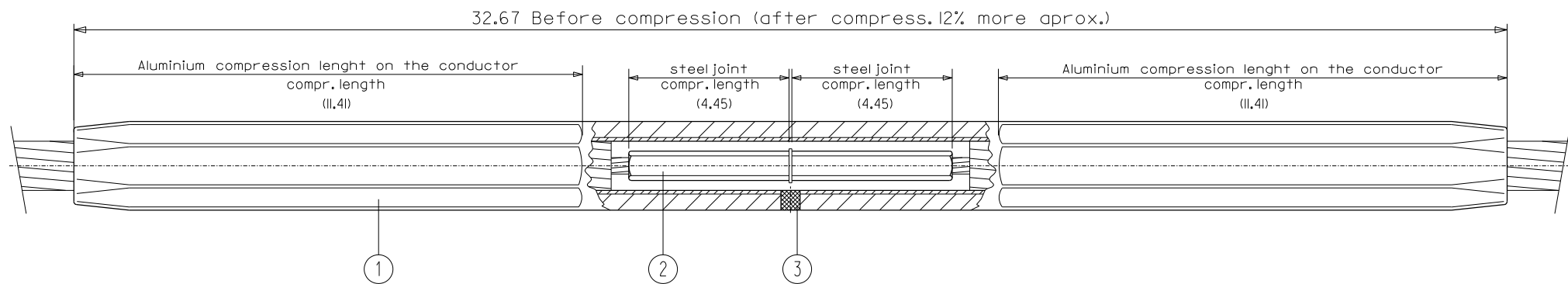

MARKS	
-	▲ & LOT
-	REFERENCE OF THE CLAMP
-	CONDUCTOR NAME
-	MIN. RECOMMENDED PRESS
-	DIE SIZE
-	COMPRESSION AREA

DIMENSIONS BEFORE COMPR.

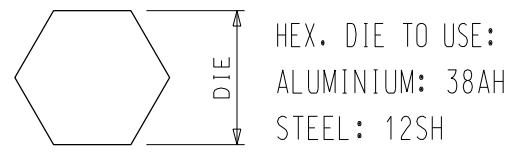
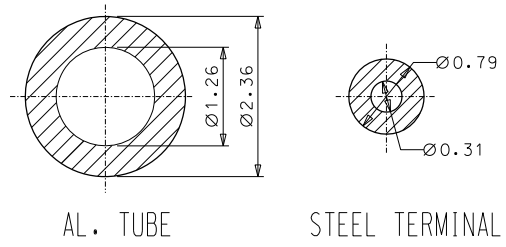

ARCHIVO:usacompression

- Notes:**
- Hot dip galvanized according to ASTM A153
  - Tolerances unless otherwise stated to be up to and including 1.4" ±0.027 Over 1.4" ±2%
  - All dimensions in inches

3	1	FILLER PLUG	ALUMINIUM
2	1	STEEL JOINT BODY	STEEL GALVANIZED
1	1	ALUMINIUM JOINT BODY	ALUMINIUM
N	QTY	DENOMINATION	MATERIAL

MOD.	DATE	MODIFICATION			DRAWN BY
 INDUSTRIAS ARRUTI S.A.		CODE			
		FULL TENSION COMPRESSION JOINT EC-515-SS/AM FOR ACSS RAIL CONDUCTOR			
		UNIT (inch)	Aprox. Weight: 9.90 lb		
			U.S.: 95% of conductor R.B.S.		
	DRAWN	J.E.	24-02-21	SCALE	DWG No
	CHECKED	I.L.	24-02-21	D/S	EC515SSAM 0
				ISSUE	