

This drawing is property of I. Arruti and must not be copied, exhibited or furnished without the written consent of I. Arruti

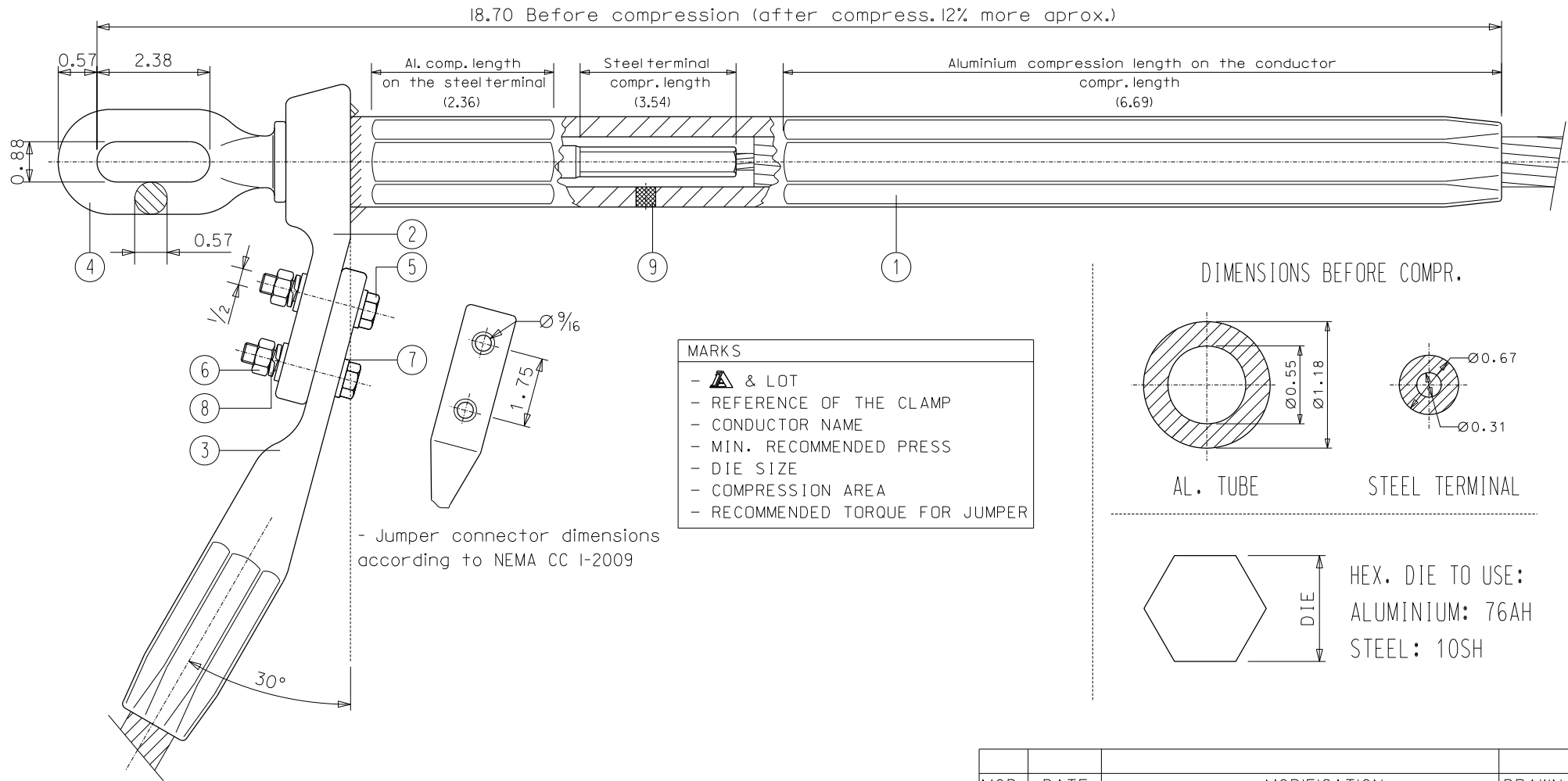

- Jumper connector dimensions according to NEMA CC I-2009

MARKS	
-	& LOT
-	REFERENCE OF THE CLAMP
-	CONDUCTOR NAME
-	MIN. RECOMMENDED PRESS
-	DIE SIZE
-	COMPRESSION AREA
-	RECOMMENDED TORQUE FOR JUMPER

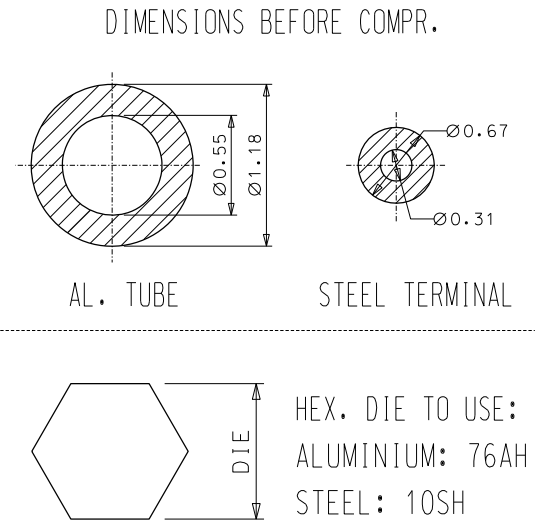

Notes:

- Both sides of the pad are finished to present excellent electrical contact surfaces
- Electrical connection pads will be supplied with a protective covering
- Hot dip galvanized according to ASTM A153
- Tolerances unless otherwise stated to be up to and including 1.4" ±0.027 Over 1.4" ±2%
- All dimensions in inches

QTY	DENOMINATION	MATERIAL
9	1 FILLER PLUG	ALUMINIUM
8	2 SPRING LOCK 1/2" ASME B18.21.I	STAINLESS STEEL
7	4 FLAT WASHER 1/2" ASME B18.21.I	STAINLESS STEEL
6	2 HEX NUT 1/2" ASME B18.2.2	STAINLESS STEEL
5	2 BOLT 1/2"x2 ASME B18.2.1	STAINLESS STEEL
4	1 EYE TERMINAL 7430-F	FORGING STEEL GALV.
3	1 JUMPER CONNECTOR DC-30	ALUMINIUM
2	1 DEAD END LUG	ALUMINIUM
1	1 CLAMP BODY	ALUMINIUM
QTY	DENOMINATION	MATERIAL

MOD.	DATE	MODIFICATION	DRAWN BY
 INDUSTRIAS ARRUTI S.A.		CODE	
		EYE TERMINAL COMPRESSION CLAMP C-89/AM-IX FOR ACSR MINORCA CONDUCTOR	
 F40513 NAME		UNIT (inch)	Recomended Torque: 35 ftlb
			Aprox. Weight: 4.20 lb
DRAWN J.E.		08-09-20	SCALE DWG No
		08-09-20	D/S C89AMIX 0
CHECKED I.L.			

ARCHIVO-usccompression