

This drawing is property of I. Arruti and must not be copied, exhibited or furnished without the written consent of I. Arruti

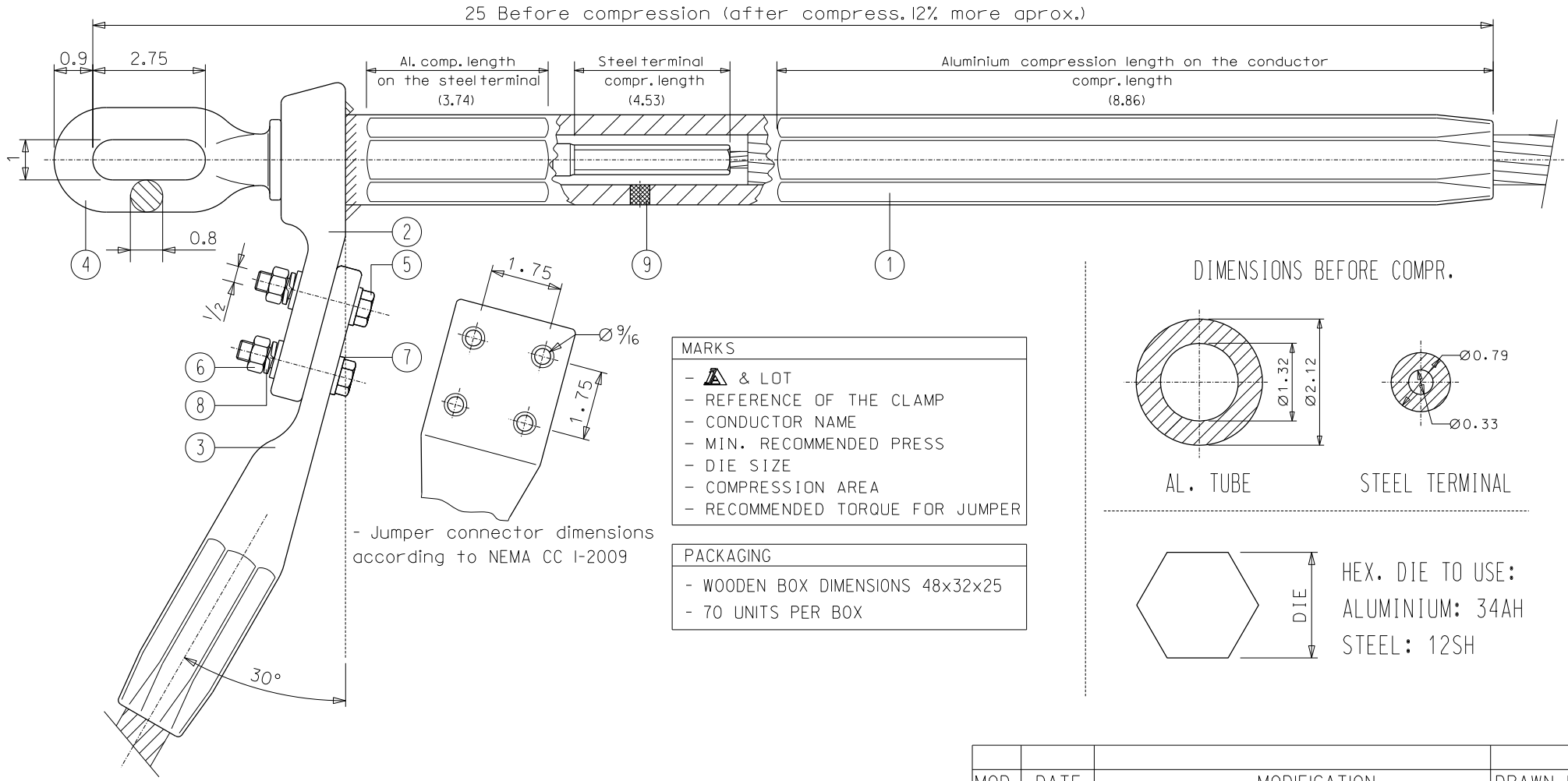

25 Before compression (after compress. 12% more aprox.)

- Jumper connector dimensions according to NEMA CC I-2009

MARKS	
-	▲ & LOT
-	REFERENCE OF THE CLAMP
-	CONDUCTOR NAME
-	MIN. RECOMMENDED PRESS
-	DIE SIZE
-	COMPRESSION AREA
-	RECOMMENDED TORQUE FOR JUMPER

PACKAGING	
-	WOODEN BOX DIMENSIONS 48x32x25
-	70 UNITS PER BOX

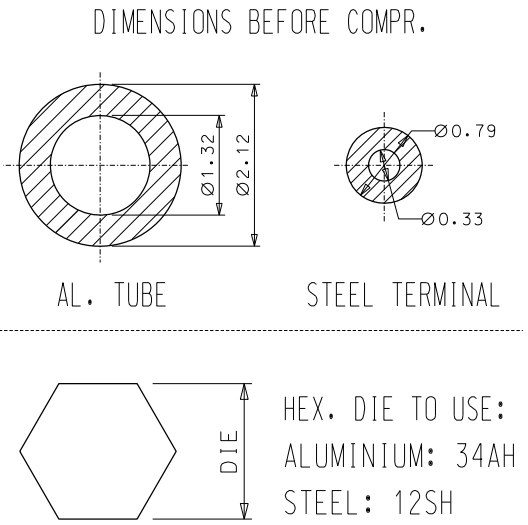

Notes:

- Both sides of the pad are finished to present excellent electrical contact surfaces
- Electrical connection pads will be supplied with a protective covering
- Hot dip galvanized according to ASTM A153
- Tolerances unless otherwise stated to be up to and including 1.4" ±0.027 Over 1.4" ±2%
- All dimensions in inches

QTY	DENOMINATION	MATERIAL
9	1 FILLER PLUG	ALUMINIUM
8	4 SPRING LOCK 1/2" ASME B18.21.1	STAINLESS STEEL
7	8 FLAT WASHER 1/2" ASME B18.21.1	STAINLESS STEEL
6	4 HEX NUT 1/2" ASME B18.2.2	STAINLESS STEEL
5	4 BOLT 1/2"x2.5 ASME B18.2.1	STAINLESS STEEL
4	1 EYE TERMINAL	FORGING STEEL GALV.
3	1 JUMPER CONNECTOR DC-54	ALUMINIUM
2	1 DEAD END LUG	ALUMINIUM
1	1 CLAMP BODY	ALUMINIUM

MOD.	DATE	MODIFICATION	DRAWN BY
 INDUSTRIAS ARRUTI S.A.		CODE	
		EYE TERMINAL COMPRESSION CLAMP C-603/AM-IX FOR ACSR BLUEJAY CONDUCTOR	
F40513		NAME	
DRAWN	J.E.	UNIT (inch)	
CHECKED	I.L.	Recomended Torque: 35 ftlb Aprox. Weight: 12.00 lb U.S.: 95% of conductor R.B.S.	
		09-09-20	SCALE
		09-09-20	DWG No
		D/S	C603AMIX
			ISSUE
			0

ARCHIVO: usocompression