

This drawing is property of I. Arruti and must not be copied, exhibited or furnished without the written consent of I. Arruti

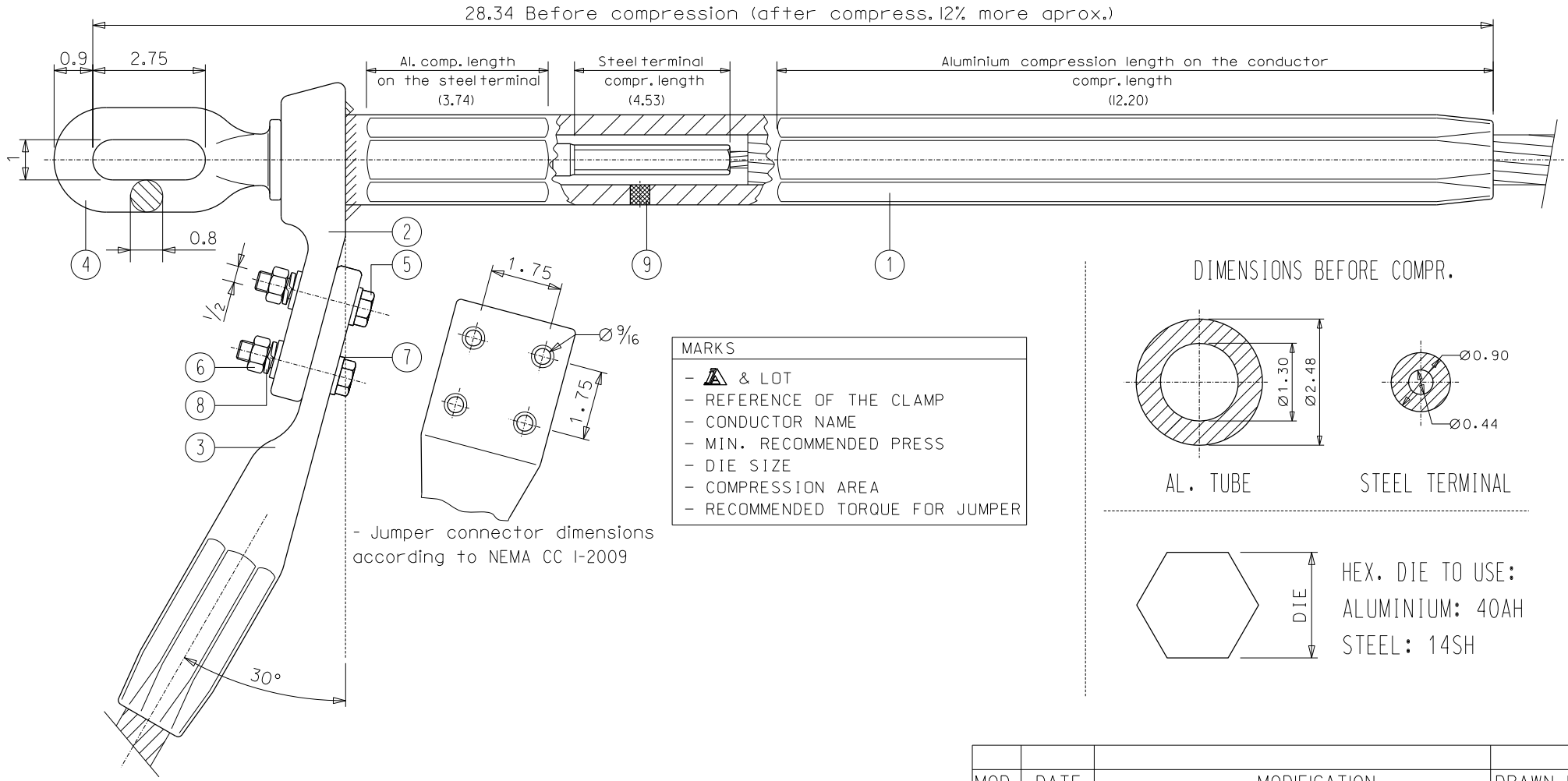

| MARKS | |
|-------|-------------------------------|
| - | ▲ & LOT |
| - | REFERENCE OF THE CLAMP |
| - | CONDUCTOR NAME |
| - | MIN. RECOMMENDED PRESS |
| - | DIE SIZE |
| - | COMPRESSION AREA |
| - | RECOMMENDED TORQUE FOR JUMPER |

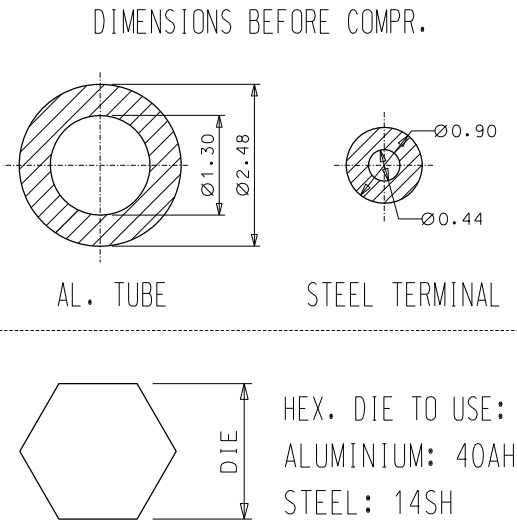

Notes:

- Both sides of the pad are finished to present excellent electrical contact surfaces
- Electrical connection pads will be supplied with a protective covering
- Hot dip galvanized according to ASTM A153
- Tolerances unless otherwise stated to be up to and including 1.4" mm. ±0.7 mm. Over 1.4" mm. ±2%
- All dimensions in inches

| QTY | DENOMINATION | MATERIAL |
|-----|----------------------------------|---------------------|
| 9 | 1 FILLER PLUG | ALUMINIUM |
| 8 | 4 SPRING LOCK 1/2" ASME B18.21.1 | STAINLESS STEEL |
| 7 | 8 FLAT WASHER 1/2" ASME B18.21.1 | STAINLESS STEEL |
| 6 | 4 HEX NUT 1/2" ASME B18.2.2 | STAINLESS STEEL |
| 5 | 4 BOLT 1/2"x2.5 ASME B18.2.1 | STAINLESS STEEL |
| 4 | 1 EYE TERMINAL 7470-F | FORGING STEEL GALV. |
| 3 | 1 JUMPER CONNECTOR DC-63 | ALUMINIUM |
| 2 | 1 DEAD END LUG | ALUMINIUM |
| 1 | 1 CLAMP BODY | ALUMINIUM |

| MOD. | DATE | MODIFICATION | DRAWN BY |
|---|------|---|------------------|
| | | CODE | |
| | | EYE TERMINAL COMPRESSION CLAMP C-590-SS/AM-IX FOR ACSS CURLEW CONDUCTOR | |
| | | Recomended Torque: 35 ftlb | |
| | | Aprox. Weight: 19.80 lb | |
| F40513 NAME DRAWN J.E. CHECKED I.L. | | U.S.: 95% of conductor R.B.S. | |
| | | 09-09-20 | SCALE |
| | | 09-09-20 | D/S C590SSAMIX 0 |

ARCHIVO-usccompression