

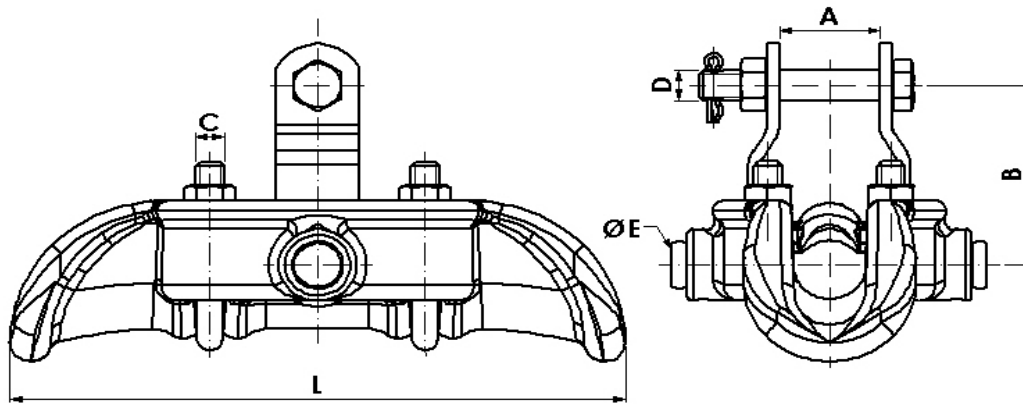

Industrias Arruti

FREE CENTER SUSPENSION CLAMPS



Application: Conductors AAAC, AAC, ACSR, ... (Conductors Al, and Al-Ac).  
 Material: Body: Alloy Al, EN-1706 (similar to ANSI A413.0).  
 Steel parts finish: Hot dip galvanising ASTM A153.

Bolt: ASTM A325.  
 Nuts: ASTM A563.  
 Lockin pins: Stainless steel.  
 Extension link: Steel plate.

Reference	Ø Conductor		Dimensions (inch)						U-Bolts Nº	Tightening Torque (ftlb)	Ultimate strength (lb)	Weight (lb)
	Min.	Max.	A	B	C	D	E	L				
GST-4/AM	0.67	1.02	1.57	3.74	1/2	5/8	5/8	10.83	2	30	22,000	5.29
GST-5/AM	0.91	1.38	1.93	3.74	4/7	5/8	5/8	11.81	2	45	27,000	6.28
GST-6/AM	1.38	1.85	2.28	3.74	4/7	5/8	5/8	12.99	2	45	27,000	6.61

NOTE: The clamps can be provided with stainless steel fasteners (except connection screw to fitting string).  
 Other kinds of fasteners upon request.