

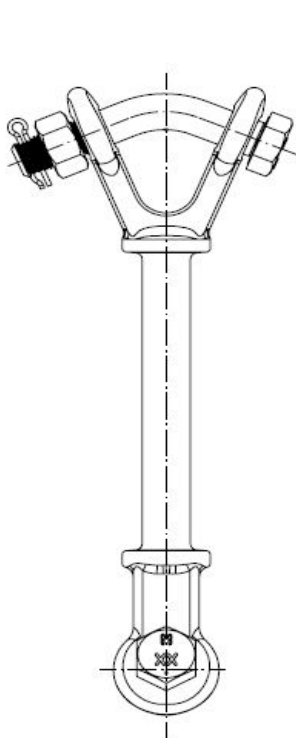

Industrias Arruti

6.7 HOT LINE Y-Y CLEVIS



HV-HVR

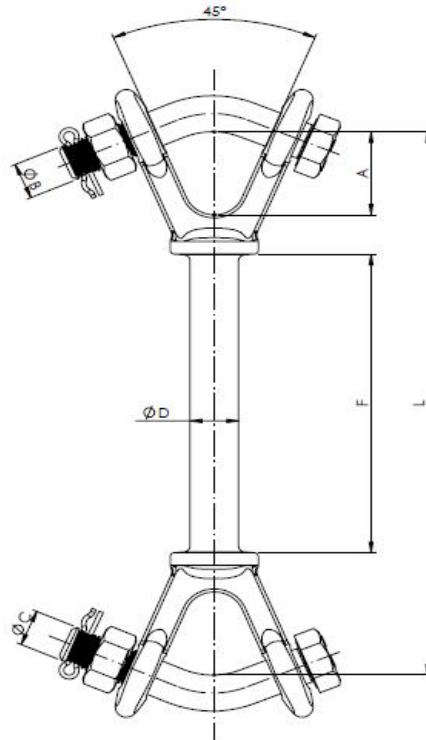

HV-HV



Material: Forged steel EN-10083 (Equivalent to ASTM A576).							Locking pin: Stainless steel.	
Steel parts finish: Hot dip galvanising ASTM A153.								
Reference	Dimensions (Inch)						Ultimate Strength	Weight
	A	B	C	D	F	L	(lb)	(lb)
HV-HV-5-L	1-5/8	3/4	5/8	7/8	6-1/4	10-3/8	30,000	4.62
HV-HV-5-L-(R)	1-5/8	3/4	5/8	7/8	6-1/4	10-3/8	30,000	4.62
HV-HV-8-L	1-5/8	7/8	3/4	1-1/8	6-1/4	10-1/8	50,000	9.34
HV-HV-8-L-(R)	1-5/8	7/8	3/4	1-1/8	6-1/4	10-1/8	50,000	9.34

Note: Special fasteners upon request.
 Bolt: ASTM A325 / Nuts: ASTM A563