

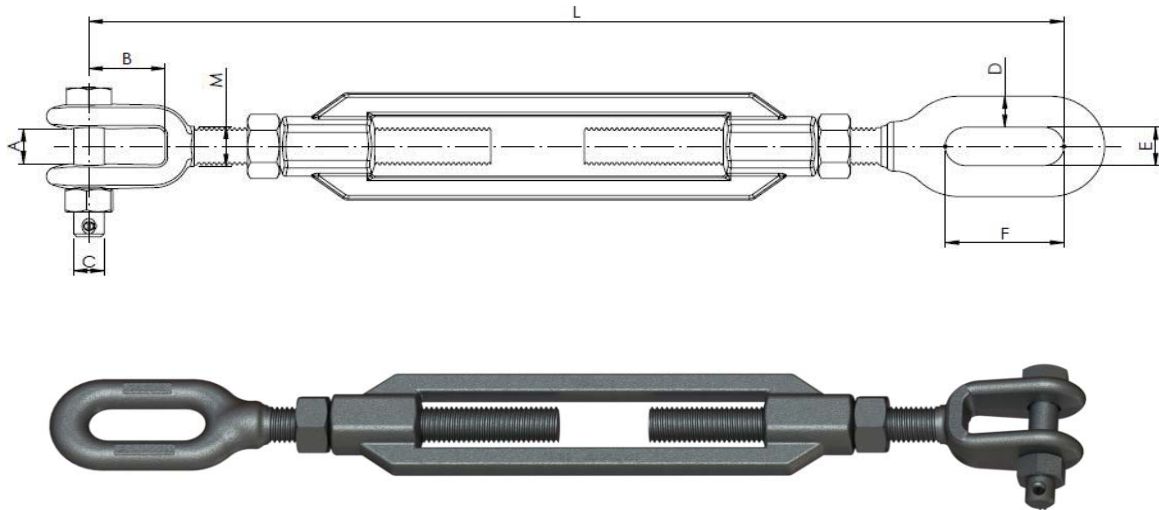

Industrias Arruti

02 TURNBUCKLE CLEVIS-EYE



Reference	Dimensions (Inch)							L		Ultimate Strength	Weight
	A	B	C	D	E	F	M	Min	Max	(lb)	(lb)
	TR-16/AH/AM	29/32	1-1/2	5/8	25/32	63/64	2-3/4	3/4	19.31	26.38	28,000
TR-20/AH/AM	29/32	1-3/4	3/4	25/32	63/64	2-3/4	3/4	20.75	28.00	36,000	9.28
TR-20/AH/M18M	29/32	1-25/32	7/8	25/32	63/64	2-3/4	7/8	19.68	26.77	50,000	10.78

NOTE: Other dimension "E" can be manufactured upon request.
Special fasteners upon request.

Material: Steel plate EN-10083 (Equivalent to ASTM A576).
Steel parts finish: Hot dip galvanising ASTM A153.
Locking pin: Stainless Steel (AISI 304)
Bolt: ASTM A325
Nut: ASTM A563